

T. Overview of pressure transmitters

Technical explanations for pressure transmitters

from page 138

Selection matrix

A guide to choosing the correct pressure transmitter

from page 143

Pressure Transmitters with ceramic measuring cell



T.1

T.1 Pressure transmitters, Performance series, hex 24

from page 144

Standard pressure ranges:	0 – 2 bar, 0 – 4 bar, 0 – 10 bar, 0 – 16 bar, 0 – 40 bar, 0 – 100 bar, 0 – 250 bar
Overpressure protection:	2 x
Output signal (alternative):	0 – 10 V or 4 – 20 mA
Housing materials:	Stainless steel 1.4305 (AISI 303)
Sealing materials:	NBR, EPDM, FKM, TPE
Threads:	G 1/4 E, NPT 1/4
Types:	0601, 0602

Pressure Transmitters with oil-filled measuring cell



T.2

T.2 Robust pressure transmitter, hex 22, stainless steel „303“

from page 148

Standard pressure ranges:	-1 – 0 bar (vacuum), -1 – 1 bar (compound) 0 – 1 bar, 0 – 4 bar, 0 – 6 bar, 0 – 10 bar, 0 – 16 bar, 0 – 40 bar, 0 – 100 bar
Overpressure protection:	2 x
Output signal (alternative):	0.5 – 4.5 V ratiometric or 0 – 10 V or 4 – 20 mA
Housing materials:	Stainless steel 1.4305 (AISI 303)
Sealing materials:	NBR, EPDM, FKM
Thread:	G 1/4 E
Types:	0645, 0650, 0660



T.3

T.3 Robust pressure transmitter, hex 22, stainless steel „316L“

from page 152

Standard pressure ranges:	-1 – 0 bar (vacuum), -1 – 1 bar (compound) 0 – 1 bar, 0 – 4 bar, 0 – 6 bar, 0 – 10 bar, 0 – 16 bar, 0 – 40 bar, 0 – 100 bar
Overpressure protection:	2 x
Output signal (alternative):	0.5 – 4.5 V ratiometric or 0 – 10 V or 4 – 20 mA
Housing materials:	Stainless steel 1.4404 (AISI 316L)
Sealing materials:	NBR, EPDM, FKM
Thread:	G 1/4 E
Types:	0675, 0680, 0690

Pressure Transmitters with SoS technology



T.4 Pressure transmitters, High-Performance series, hex 22 from page 156

Standard pressure ranges: 0 – 10 bar, 0 – 16 bar, 0 – 25 bar, 0 – 40 bar,
0 – 60 bar, 0 – 100 bar, 0 – 160 bar,
0 – 250 bar, 0 – 400 bar, **0 – 600 bar**

Overpressure protection: Up to 4 x
Output signal (alternative): 0.5 – 4.5 V ratiometric or
0 – 10 V or
4 – 20 mA

Housing materials: Stainless steel 1.4305 (AISI 303)
Sealing materials: **All welded, without elastomeric seal**
Thread: different male threads
Types: **0705, 0710, 0720**



Pressure Transmitters with CAN-Bus interface

CAN J1939

CANopen

T.5 Digital pressure transmitters, CANopen / J1939-Protocol, hex 22 from page 160

Standard pressure ranges: 0 – 1 bar, 0 – 2.5 bar, 0 – 4 bar, 0 – 6 bar,
0 – 10 bar, 0 – 16 bar, 0 – 25 bar, 0 – 40 bar,
0 – 60 bar, 0 – 100 bar, 0 – 160 bar, 0 – 250 bar,
0 – 400 bar, 0 – 600 bar

Overpressure protection: Up to 2 x
Output protocol: **CANopen** DIN EN 50325-4
CAN J1939 SAE J1939

Housing materials: Stainless steel 1.4301 / AISI 304
Sealing materials: **All welded, without elastomeric seal**
Electrical connection: M12 DIN EN 61076-2-101 A,
CIA-DR303-1

Thread: G 1/4 E, NPT 1/4
Types: **0630, 0631**



T.6 Accessories from page 164

- Mating plugs
- Thread-Adapters
- Display



Technical explanations for pressure transmitters

What is a pressure transmitter?

A pressure transmitter (also called pressure transducer or pressure converter) is a component used to convert a pneumatic or hydraulic pressure to an electric (usually analogue and linear) output signal, such as a current or voltage.

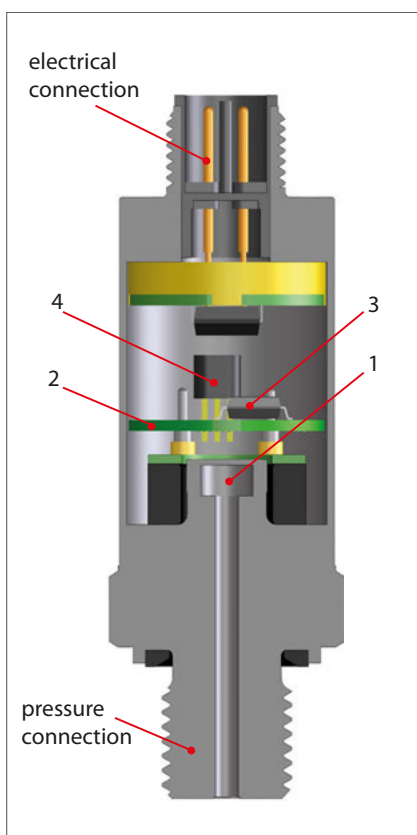

How does a pressure transmitter work?

The pressure measuring cell fitted has a membrane (1) that is exposed to the pressure to be measured. Affixed on this membrane is a bridge circuit consisting of four ohmic resistors in the form of a Wheatstone bridge. The values of these resistors change proportionally to the pressure load present at the measuring cell or membrane. The bridge voltage of the measuring cell is amplified in the evaluation electronics (2) and processed digitally by a microcontroller (3).

The downstream output stage (4) converts this signal to the output signal required (such as 4 - 20 mA or 0 - 10 V).

SoS technology

In the silicone-on-sapphire technology, the substrate of the thin film measuring cell is synthetic sapphire. This has excellent mechanical and temperature stable properties and prevents undesired parasitic effects, thereby having a positive effect on accuracy and stability. In conjunction with a titanium membrane, this results in virtually unique coaction between the temperature coefficients of sapphire and titanium.

This is because, unlike silicon and stainless steel, they are more closely matched and so only require a low level of compensation overhead. This also has a favourable effect on long-term stability.

„Oil-filled“ stainless steel measuring cell

In this measuring cell technology, the piezo-resistive measuring cell is packaged within a metallic housing filled with fluorine oil. This means the measuring cell is virtually free of external mechanical stress. Fluorine oil has excellent characteristics in regards to temperature and ageing behaviour, and is not flammable and so fits perfectly to oxygen applications. It is not recommended for food applications.

Ceramic measuring cell / thick film technology

Ceramic thick film pressure measuring cells are made up of a sintered ceramic body. The ceramic body sleeve already has the key geometries for the subsequent pressure range. The membrane thickness required and thus, the pressure range required is established with grinding and lapping. The resistors are imprinted with thick film technology and interconnect to form a measuring bridge.

Standard signals

Output signals 4 - 20 mA, 0 - 10 V and 0.5 - 4.5 V ratiometric in particular have established themselves in the industry. SUCO also offers transmitters with customer-specific output signals (such as 1 - 5 V).

Block diagram:

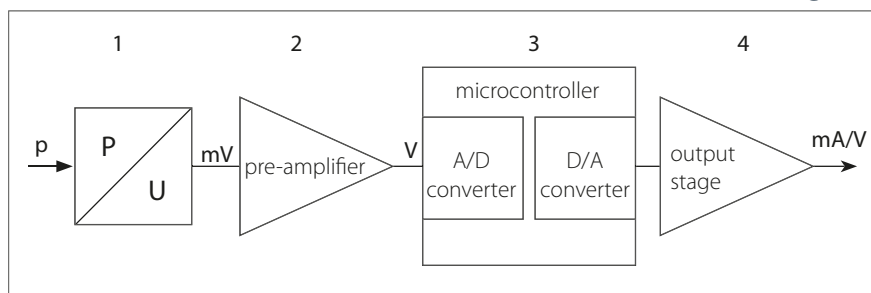

Voltage output 0 - 10 V

Transmitters with an output signal of 0 to 10 V are a commonly used variant due to their simple initial operation and straightforward scaling of the signal (0 V for 0 bar). The output load must be selected as highly resistive (with typical minimum value 4.7 kΩ). SUCO transmitters with voltage output have a 3-wire design.

The maximum connection length should not exceed 30 m to prevent significant voltage drops in the signal line.

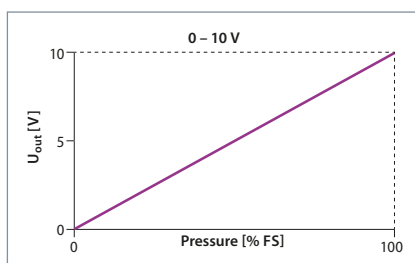

Conversion formula for pressure and voltage:

$$U_{\text{out}} = \frac{\text{pressure applied}}{\text{pressure range}} \times 10 \text{ V}$$

Voltage output

0.5 – 4.5 V ratiometric

SUCO transmitters with ratiometric output are operated with a 5 V supply voltage as 3-wire configuration. The output signal is directly proportional to / dependent on the supply voltage; this is known as a ratiometric dependency. 0.5 – 4.5 V is established as an output voltage because many A/D converters work with reference voltage U_{V+} of 5 V. The output voltage 0.5 V equals to 10% and 4.5 V corresponds to 90% of the supply voltage. The span is therefore 80% of the supply voltage.

This variant is used for example when a transmitter and a downstream A/D converter as an evaluation unit are to be powered with the same reference / operating voltage.

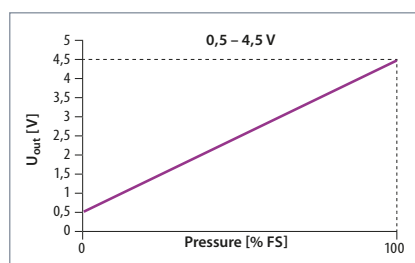

Conversion formula for pressure and voltage:

$$U_{\text{out}} = 0.1 \times U_{V+} + \frac{\text{pressure applied}}{\text{pressure range}} \times 0.8 \times U_{V+}$$

with U_{V+} = operating voltage

Current output 4 – 20 mA

The most common analogue output signal of sensors is 4 – 20 mA current output (as 2-wire configuration). The advantage of a 4 – 20 mA output signal is the 4 mA offset which allows the monitoring of potential wire break and short-circuit (life zero signal).

The signal can also be transmitted over long distances with no loss in accuracy. This variant is also the least sensitive to EMC factors. 2-wire technology also means wiring overhead is reduced.

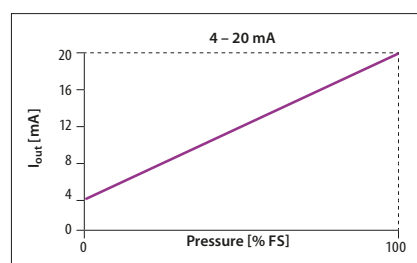

Conversion formula for pressure and voltage:

$$I_{\text{out}} = 4 \text{ mA} + \frac{\text{pressure applied}}{\text{pressure range}} \times 16 \text{ mA}$$

Output for vacuum transmitters

As depicted in the sketch on the upper right, the output is at maximum signal at zero pressure. Therefore at maximum vacuum the output signal is at its minimum.

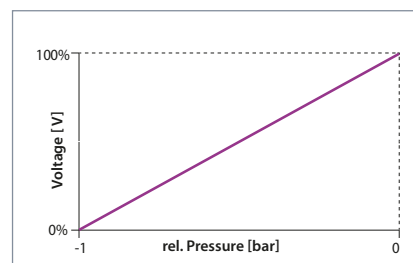

Load / apparent ohmic resistance for pressure transmitters

An appropriate ohmic load must be connected to guarantee perfect functioning of a pressure transmitter.

For transmitters with a voltage output (V), the load should be at least 4.7 kΩ.

For transmitters with a current output (4 - 20 mA), the maximum load is calculated using the following formula:

$$R_L = \frac{U_{V+} - U_{V+(min)}}{20 \text{ mA}}$$

$U_{V+(min)}$ is the minimum supply voltage - to be taken from the data sheet. $U_{V+(min)} = 10 \text{ V}$ gives the following operating range for example:

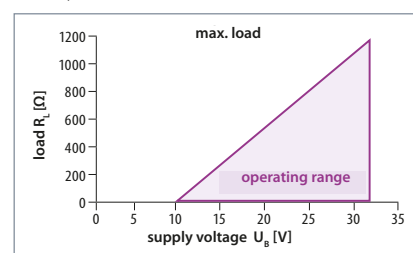

Supply / operating voltage UB

All pressure transmitters work with DC voltage and have no galvanic isolation. Within the thresholds specified in the relevant data sheet, the supply voltage may change without influencing the output signal. (the ratiometric variant is an exception).

To guarantee the functionality of a transmitter, the minimum supply voltage may not fall below. The maximum operating voltage may not be exceeded to avoid damage on the electronics.

Technical explanations for pressure transmitters

Accuracy (to DIN EN 61298)

The (measuring) accuracy of pressure transmitters is specified by SUCO as $\pm 0.5\%$ or $\pm 1\%$ of the span (also called full scale). Accuracy includes zero point offset, non-linearity, hysteresis and non-repeatability, and is defined at room temperature and new state. This method defines the maximum deviation from the ideal line (in contrast to the BFSL method in which the average deviation is given). Other factors influencing the total accuracy, such as temperature and ageing, are specified separately.

Non-linearity (to DIN EN 61298)

Non-linearity (also linearity) defines the deviation of the actual output curve from the theoretical ideal line. SUCO specifies the maximum error in relation to the overall span or full scale (FS) of the pressure range.

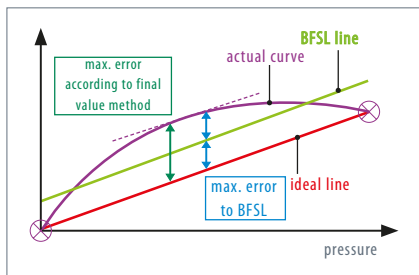

Non-linearity is also shown as BFSL (Best Fit Straight Line) as a reference value in the technical specifications. Non-linearity generally has the biggest influence on the overall error rate. Typically, non-linearity as per BFSL corresponds to half of non-linearity as per the full scale method ($1\% \text{ FS} \sim 0.5\% \text{ BFSL}$).

Hysteresis (to DIN EN 61298)

For a pressure transmitter, hysteresis specifies the difference of output signal between a rising and falling pressure, and is typically very low and negligible for SUCO pressure transmitters.

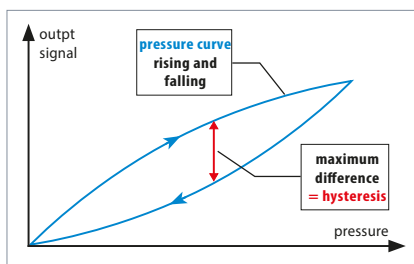

Non-repeatability (to DIN EN 61298)

Non-repeatability defines reproducibility of the output signal. The pressure is attained three times for example - the maximum variance between these three values gives the non-repeatability.

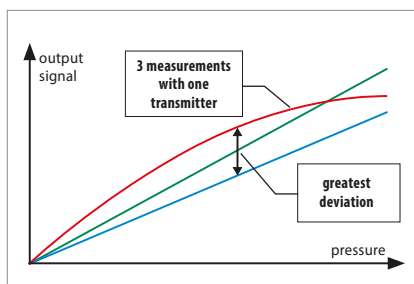

Temperature errors and ranges

The temperature (both of the medium and ambience) generally has a significant influence on the accuracy of a pressure transmitter. Pressure transmitters are temperature compensated over a particular range corresponding to the typical application. This means that temperature errors within this temperature range are minimised by means of circuitry design and algorithms. The temperature error is added to the accuracy, and shown in the total error band of the pressure transmitter, also called butterfly graph. Outside the compensated temperature range, the maximum error is not defined, however the pressure transmitter still functions.

To prevent mechanical and electrical damage, pressure transmitters may not be deployed beyond the threshold temperature ranges specified in the data sheet.

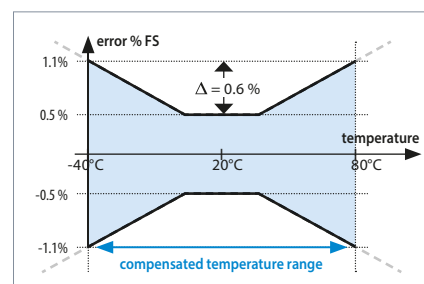

Service life and long-term stability

Service life information pertains to nominal conditions specified in the data sheet, and can vary considerably when a product is operated mechanically or electrically outside the specifications. Service life essentially depends on the used measuring cell technology.

Ageing is accelerated (or slowed) due to different factors - such as temperature, temperature change and reduction of mechanical forces. The occurrence of ageing does effect the total accuracy.

SUCO specifies long-term stability in accordance with DIN 16086 in relation to one year. Typically the influence of aging on the accuracy reduces with increasing operating duration. The information in the data sheet corresponds to the worst case scenario.

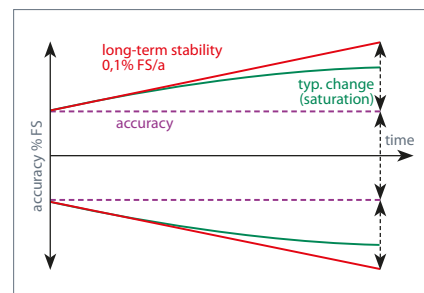

Resolution

The A/D resolution (analogue - digital) of an pressure transmitter defines the smallest change of the analogue - digital - analogue conversion which takes places by the signal processing of an pressure transmitter.

If for example 13-bit resolution is used for an pressure transmitter with a 100 bar setting range, the smallest signal change is 8192 steps (2^{13}). As state of the art a resolution of 12 bits and hence 4096 steps (2^{12}) is typical. Therefore pressure changes of 100 bar / 4096 = 0.024 bar can be recorded.

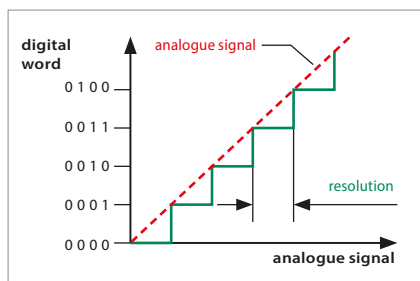

Sampling rate

The sampling rate (or sampling frequency) defines the number of samples per time unit (typically in seconds or milliseconds) taken from an analogue signal and converted to a digital signal. The sampling rate is an indicator of how fast the output signal of a pressure transmitter responds to the pressure change at the input.

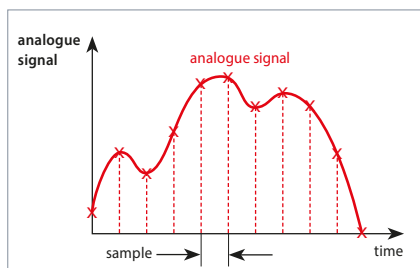

Response time

The response or circuit time is shorter than 2 to 4 milliseconds (depending on model). The sum of A/D and D/A conversions, and the analogue and digital filters in the signal chain from the measuring bridge to the output, make up the response time. Filtering is used to suppress unwanted pressure peaks and electrical interference signals, and for good EMC characteristics.

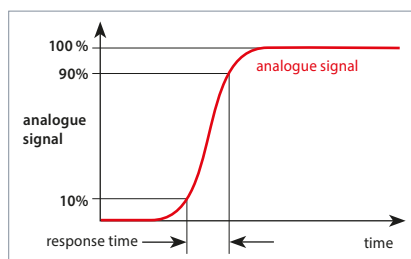

CE mark

Pressure transmitters from SUCO fall under the 2014/30/EU EMC Directive.

EC declarations of conformity have been issued for the pressure transmitters are available on request or can be downloaded from our website. The relevant devices are denoted by a CE mark in our catalogue.

The Machinery Directive 2006/42 EC is not applicable, because our products are classed as components. Our products are designed for Group 2 fluids based upon good engineering practise in line with Pressure Equipment Directive 2014/68/EU, meaning neither a declaration of conformation may be issued nor a CE mark affixed.

Electromagnetic compatibility (EMC)

Pressure transmitters from SUCO do comply to all important industrial EMC standards. The basis for the standards are the stricter thresholds for transient emissions in residential environments (EN 61000-6-3) and immunity for industrial environments (EN 61000-6-2).

Generic standard	Test standard	Parameter(s)
Radio disturbance and immunity	EN 55016-2-1 EN 55016-2-3	60 dBuV
Radiated, high-frequency electromagnetic field immunity test	EN 61000-4-3	10 V/m; 80-1000 MHz, 3 V/m; 1400-2000 MHz, 1 V/m; 2000-2700 MHz
Immunity to conducted disturbances, induced by radio-frequency fields	EN 61000-4-6	10 V; 0,15-80 MHz
Electrical fast transient / burst immunity test	EN 61000-4-4	±2 kV
Surge immunity test	EN 61000-4-5	±0,5 kV (common) ±0,5 kV (differential)
Electrostatic discharge (ESD) immunity test	EN 61000-4-2	air: 8 kV with contact: 4 kV

Technical explanations for pressure transmitters

Conversion chart for pressure units

Abbreviation for unit	Name of unit	Pa = N/m ²	bar	Torr	lbf/in ² , PSI
1 Pa = N/m ²	Pascal	1	0.00001	0.0075	0.00014
1 bar	Bar	100 000	1	750.062	14.5
1 Torr = 1 mmHg	Millimeters of mercury	133.322	0.00133	1	0.01934
1 lbf/in ² = 1 PSI	Pound-force per square inch	6894	0.06894	51.71	1

Conversion chart for temperature units

	K	°C	F
K	1	K - 273.15	9/5 K - 459.67
°C	°C + 273.15	1	9/5 °C + 32
F	5/9 (F + 459.67)	5/9 (F - 32)	1

Insulation strength

According to the latest specifications for immunity to surges and lightning protection, the following must be taken into account when testing insulation strength: With insulation test devices having an inner resistance exceeding 42 Ω, the insulation strength of pressure transmitters can be tested up to 500 VDC.

All contacts must be tested short-circuited against the housing. For a specific threshold value of test voltage, the protective circuit for surge protection is activated without any defects arising within the circuit. In the process, the current may rise to a point at which an insulation strength fault is indicated. The recommendation therefore is to conduct the insulation test of the pressure transmitter when it is removed, or independently of the overall system.

Medium compatibility

The specifications on medium compatibility in this catalogue pertain to the specific seal and housing materials as well as the used measuring cell technology and so cannot be generalised.

Stainless steel (1.4301 / AISI 304)

Stainless steel with broad level of media compatibility, such as water, steam, humidity and weak organic and inorganic acids

Stainless steel (1.4305 / AISI 303)

Stainless steel with broad level of media compatibility. Also suitable for oxygen and hydrogen applications.

Stainless steel (1.4404 / AISI 316L)

Stainless steel with broad level of media compatibility. Also suitable for chemical industry and sea water applications.

Titanium

Its high levels of mechanical resistance and the wide media compatibility – in particular to corrosive media – do make titanium the ideal material for measuring cells and membranes. It is not recommended for oxygen or hydrogen applications.

Oxygen and hydrogen

It is recommended to use an EPDM seal for the media oxygen / hydrogen to be monitored.

The EPDM seal of the „Performance“ series (pp. 144-147) was successfully tested at the BAM (Federal Institute for Materials Testing) up to 250 bar by means of an oxygen pressure shock test at 60 °C.

EPDM must not come into contact with oil, as this results in swelling and softening of the material and thus the failure of the transmitter.

Country-specific safety requirements and application guidelines must be observed if the medium to be monitored is oxygen or hydrogen, such as DGUV accident prevention regulations (DGUV 500, Section 2.32 and BGI 617).

Please specify when ordering „for oxygen, oil and grease-free“ or order plasma cleaned and individually packaged transmitters (see also „Plasma cleaning for oxygen applications / LABS-free (PWIS-free)“ on page 9).

Pressure peak dampening

If required, our pressure transmitters can also be fitted with a pressure snubber (pressure peak orifice) to protect the measuring cell against transient pressure loads such as pressure peaks due to the switching of valves, cavitation effects, etc. which can shorten life expectancy.

For liquid media, the hole of a pressure snubber cannot be chosen to be any small size. At low temperatures the viscosity of the media will increase. In a case of dropping pressure the media might remain in the cavity behind the snubber which might affect the functionality of the pressure transmitter. Thus a bore diameter of 0.8 mm has been established.

Product information

The technical information in this catalogue is based upon fundamental testing during product development, as well as upon empirical values. The information cannot be used for all application scenarios.

Testing of the suitability of our products for a specific application (e.g. also the checking of material compatibilities) falls under the responsibility of the user. It may be the case that suitability can only be guaranteed with appropriate field testing.

Subject to technical changes.

Selection matrix for pressure transmitters

Type / series		0601	0602	0645	0650	0660	0675	0680	0690	0705	0710	0720	0630	0631
Page		147	147	151	151	151	155	155	155	159	159	159	163	163
Measuring cell technology	stainless steel, oil-filled, piezo-resistive			■	■	■	■	■	■					
	stainless steel, piezo-resistive												■	■
	ceramic / thick-film	■	■											
	SoS / titanim									■	■	■		
Function	overpressure	■	■	■	■	■	■	■	■	■	■	■	■	■
	vacuum			■	■	■	■	■	■					
Output	0.5 - 4.5 V ratiometric			■			■			■				
	0 - 10 V	■			■			■			■			
	4 - 20 mA		■			■			■			■		
	CAN												■	■
Operating voltage	5 VDC ± 10 %			■			■			■				
	(9.6 ... 12) - 32 VDC	■	■		■	■		■	■		■	■	■	■
Pressure range	-1 - 0 bar			■	■	■	■	■	■					
	-1 - 1 bar (compound)			■	■	■	■	■	■					
	0 - 1 bar			■	■	■	■	■	■				■	■
	0 - 2 bar	■	■											
	0 - 2.5 bar												■	■
	0 - 4 bar	■	■	■	■	■	■	■	■				■	■
	0 - 6 bar			■	■	■	■	■	■				■	■
	0 - 10 bar	■	■	■	■	■	■	■	■	■	■	■	■	■
	0 - 16 bar	■	■	■	■	■	■	■	■	■	■	■	■	■
	0 - 25 bar									■	■	■	■	■
	0 - 40 bar	■	■	■	■	■	■	■	■	■	■	■	■	■
	0 - 60 bar									■	■	■	■	■
	0 - 100 bar	■	■	■	■	■	■	■	■	■	■	■	■	■
	0 - 160 bar									■	■	■	■	■
	0 - 250 bar	■	■							■	■	■	■	■
	0 - 400 bar									■	■	■	■	■
	0 - 600 bar									■	■	■	■	■
Overpressure protection	up to 2x	■	■	■									■	■
	up tp 3x			■	■	■	■	■	■					
	up to 4x									■	■	■		
Compensated temperature range	0 ... +70 °C	■	■											
	-10 ... +70 °C			■	■	■	■	■	■					
	-20 ... +85 °C												■	■
	-40 ... +80 °C									■	■	■		
Size	hex 22			■	■	■	■	■	■	■	■	■	■	■
	hex 24	■	■											
Housing material	stainless steel 1.4201 / AISI 304												■	■
	stainless stell 1.4305 / AISI 303	■	■	■	■	■				■	■	■		
	stainless steel 1.4404 / AISI 316L						■	■	■					
Option	suitable for oxygen (on request)	■	■	■	■	■	■	■	■					

